

Beta

581/5



 1÷5 Nm

IT Manuale d'uso ed istruzioni

EN Operation manual and instructions

FR Notice d'utilisation et instructions

DE Bedienungsanleitung

ES Manual de uso e instrucciones

PT Manual de uso e instruções

NL Gebruikshandleiding

PL Instrukcja obsługi i zalecenia

HU Használati kézikönyv és útmutató

EL Εγχειρίδιο χρήσης και οδηγίες

DA Brugervejledning og instruktioner

SL Uporabniški priročnik in navodila

SK Návod na použitie a pokyny

CS Návod k použití a pokyny

RO Manual de utilizare și instrucțiuni

BG Ръководство за потребителя и инструкции

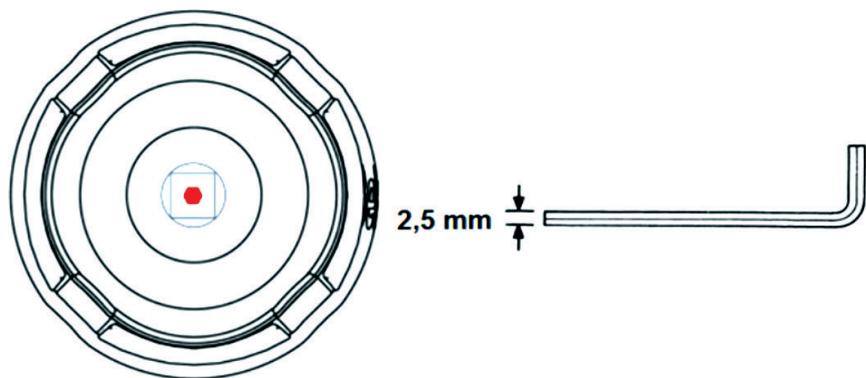
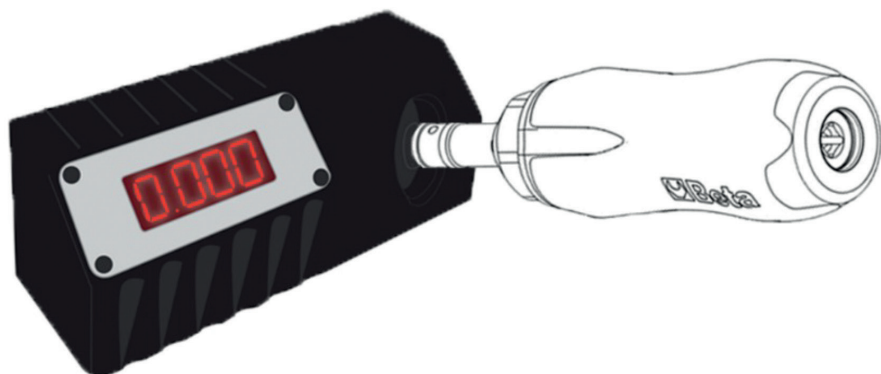
1**2****3**

ISTRUZIONI PER L'USO

IT

1. Agire sull'esagono in fondo all'impugnatura (2,5 mm)
2. Regolare la coppia desiderata
3. Verificare



Si raccomanda di far controllare la corretta taratura della chiave dopo 12 mesi di utilizzo o 5.000 cicli.

OPERATION MANUAL AND INSTRUCTIONS

EN

1. Act on the hexagon at the bottom of the handle (2.5 mm)
2. Adjust the desired torque
3. Check



Make sure that wrench calibration is tested after 12 months of operation or after 5.000 cycles.

NOTICE D'UTILISATION ET INSTRUCTIONS

FR

1. Agir sur l'hexagone au bas de la poignée (2,5 mm)
2. Régler le couple désiré
3. Vérifier



Il est recommandé de faire vérifier l'étalonnage correct de la clé après 12 mois ou 5000 cycles d'utilisation.

BEDIENUNGSANLEITUNG

DE

1. Auf den Sechskant an der Unterseite des Griffs einwirken (2,5 mm)
2. Stellen Sie das gewünschte Drehmoment ein
3. Überprüfen



Die korrekte Eichung des Schlüssels sollte nach 12 Monaten Gebrauch oder nach 5000 Zyklen kontrolliert werden.

MANUAL DE USO E INSTRUCCIONES

ES

1. Actúe sobre el hexágono situado en la parte inferior del mango (2,5 mm)
2. Ajuste el par deseado
3. Compruebe



Se recomienda mandar controlar la calibración correcta de la llave después de 12 meses de utilización o 5000 ciclos.

MANUAL DE USO E INSTRUÇÕES

PT

1. Atuar sobre o hexágono na parte inferior do punho (2,5 mm)
2. Ajustar o binário pretendido
3. Verificar



Recomenda-se mandar controlar a calibração correta da chave depois de 12 meses de utilização ou 5000 ciclos.

GEBRUIKSHANDLEIDING

NL

1. Handelen op de zeskant aan de onderkant van het handvat (2,5 mm)
2. Stel het gewenste koppel in
3. Controleer



Het wordt aanbevolen om om de 12 maanden gebruik of om de 5000 cycli te laten controleren of de sleutel nog goed afgesteld is.

INSTRUKCJA OBSŁUGI I ZALECENIA

PL

1. Naciśnąć sześciokąt w dolnej części uchwytu (2,5 mm)
2. Ustaw żądany moment obrotowy
3. Sprawdź



Zaleca się sprawdzanie prawidłowości kalibracji klucza po 12 miesiącach użytkowania lub 5000 cyklach.

HASZNÁLATI KÉZIKÖNYV ÉS ÚTMUTATÓ

HU

1. A fogantyú alján lévő hatszögre hatni (2,5 mm)
2. Állítsa be a kívánt nyomatékot
3. Ellenőrizze a címet



Tanácsoljuk, hogy 12 havonta vagy 5000 munkaciklust követően ellenőriztessük a kulcs tára beállítását

ΟΔΗΓΙΕΣ ΧΡΗΣΗΣ

EL

1. Ενεργήστε πάνω από το εξάγωνο στη βάση της λαβής (2,5 mm).
2. Ρυθμίστε την επιθυμητή ροπή
3. Ελέγξτε



Συστήνεται ο έλεγχος του σωστού καλιμπραρίσματος του κλειδιού έπειτα από 12 μήνες χρήσης ή 5000 κύκλους.

BRUGERVEJLEDNING OG INSTRUKTIONER

DA

1. Tryk på sekskanten i bunden af håndtaget (2,5 mm)
2. Juster det ønskede drejningsmoment
3. Kontroller



Det anbefales at få tjekket, om skruenøglen er korrekt kalibreret efter 12 måneders brug eller 5.000 cyklusser.

UPORABNIŠKI PRIROČNIK IN NAVODILA

SL

1. Delujite na šesterkotnik na dnu ročaja (2,5 mm)
2. Nastavite želeni navor
3. Preverite



Priporočljivo je, da po 12 mesecih uporabe ali 5.000 ciklih preverite pravilnost kalibracije ključa.

NÁVOD NA POUŽITIE A POKYNY

SK

1. Pôsobte na šesťhran v spodnej časti rukoväte (2,5 mm)
2. Nastavte požadovaný krútiaci moment
3. Skontrolujte



Správnosť kalibrácie kľúča sa odporúča skontrolovať po 12 mesiacoch používania alebo po 5 000 cykloch.

NÁVOD K POUŽITÍ A POKYNY

CS

1. Působte na šestihran ve spodní části rukojeti (2,5 mm)
2. Nastavte požadovaný krouticí moment
3. Zkontrolujte



Doporučujeme nechat klíč zkontrolovat z hlediska správné kalibrace po 12 měsících používání nebo po 5 000 cyklech.

MANUAL DE UTILIZARE ȘI INSTRUCȚIUNI

RO

1. Acționați asupra hexagonului din partea inferioară a mânerului (2,5 mm)
2. Reglați cuplul dorit
3. Verificați



Se recomandă să se verifice calibrarea corectă a cheii după 12 luni de utilizare sau 5.000 de cicluri.

РЪКОВОДСТВО ЗА ПОТРЕБИТЕЛЯ И ИНСТРУКЦИИ

BG

1. Действайте върху шестоъгълника в долната част на дръжката (2,5 мм)
2. Настройте желаня въртящ момент
3. Проверете



Препоръчително е ключът да се проверява за правилно калибриране след 12 месеца употреба или 5000 цикъла.

**BETA UTENSILI S.p.A. (HEADQUARTER)**

via Alessandro Volta, 18
20845 Sovico (MB) ITALY
Tel. +39 039.2077.1 - Fax +39 039.2010742
www.beta-tools.com

BETA BENELUX B.V.

Belder 9-B
4704 RK Roosendaal - NEDERLAND
Tel. +31.1655.34761 - Fax. +31.1655.34791
www.betabenelux.nl - info@betabenelux.nl

**BETA DO BRASIL COMERCIO DE MAQUINAS
E FERRAMENTAS LTDA**

Estrada Velha de Cotia, 480
Jardim Passargada- CEP: 06712-430
Cotia São Paulo - BRASIL
Tel: +55.11.3721.5065 - Fax: +55.11.3721.9353
www.betabrasil.com.br - betabrasil@betabrasil.com.br

**BETA INDUSTRIAL PRODUCTS TRADING
(SHANGHAI) CO. LTD**

Room 902, Building 2
No.2388 Chenhang RD, Minhang District
Shanghai, 201114, CHINA
Tel: 0086-21-58182000 - Fax: 0086-21-60251399
Hotline:4006-19-18-19
www.beta-tools.com.cn - info@beta-tools.net

BETA FRANCE SAS

163 Avenue des Tamaris
Z.I. Athélia 4
13600 La Ciotat - FRANCE
Tel. +33.491.364010
beta.france@beta-tools.com

BETAMAX KFT

Megyeri út 51
H 1044 Budapest - HUNGARY
Tel. +36.1.2702700
www.betamax.hu - info@betamax.hu

BETA IBERIA S.L.

Av Castilla 26, Nave 4
28830 San Fernando De Henares - Madrid
ESPAÑA
Tel. +34.91.6778340 - Fax +34.91.6758558
beta.iberia@beta-tools.com

BETA POLSKA SP. Z O.O.

72-002 DOŁUJE, SKARBIMIERZYCE
ul. Wiosenna 12 - POLSKA
Tel. +48.91.48.08.227 / +48.91.48.08.236
Fax: +48.91.48.08.219
www.beta-polska.pl - bok@beta-polska.pl

BETA TOOLS (UK) LTD

Unit-D Horton Enterprise Park
Hortonwood,50
Telford - Shropshire - TF1 7GZ
GREAT BRITAIN
Tel. +44.1952.677977 - Fax. +44.1952.677545
www.beta-tools.co.uk - beta.uk@beta-tools.com

BETA TOOLS USA

210 Chestnut St.
Columbia, PA 17512 - USA
Tel. +1.717.449.5044 - Fax. +1.717-449-5244
www.betatoolsusa.com
customerserviceusa@betatoolsusa.com